

LIQUIDS / SEMI-LIQUIDS

boatopack
packaging lines

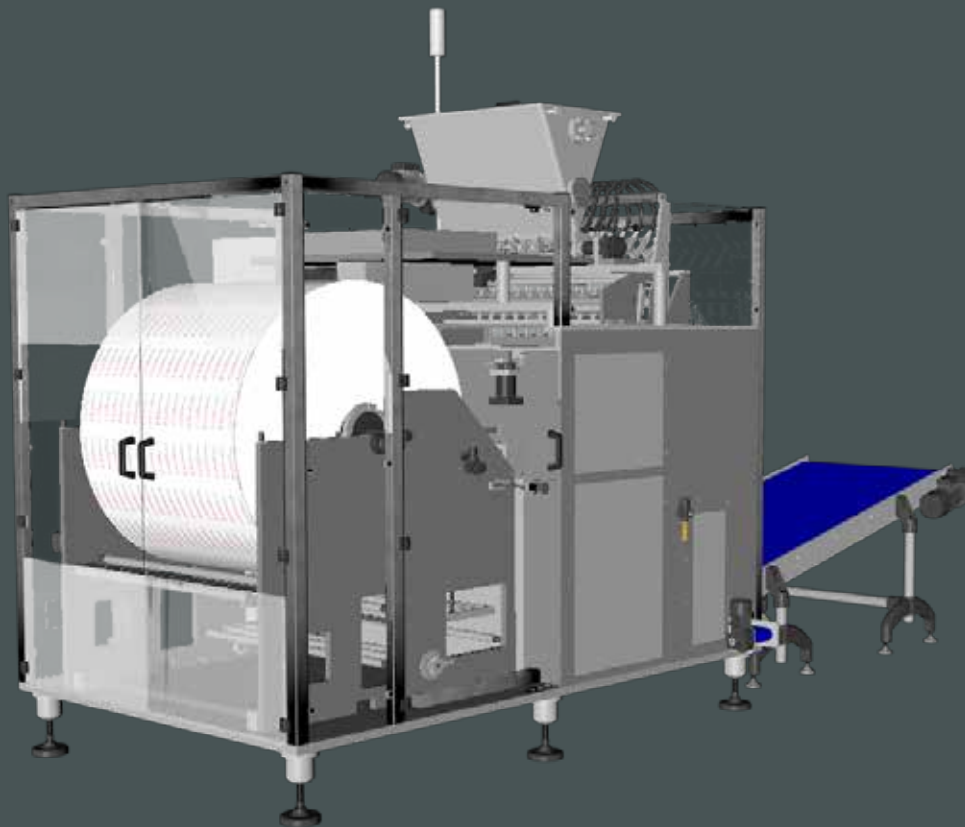

automatic packaging machines
and feeding systems

www.boatopack.com

STICK + FDCP

LIQUIDS / SEMI-LIQUIDS

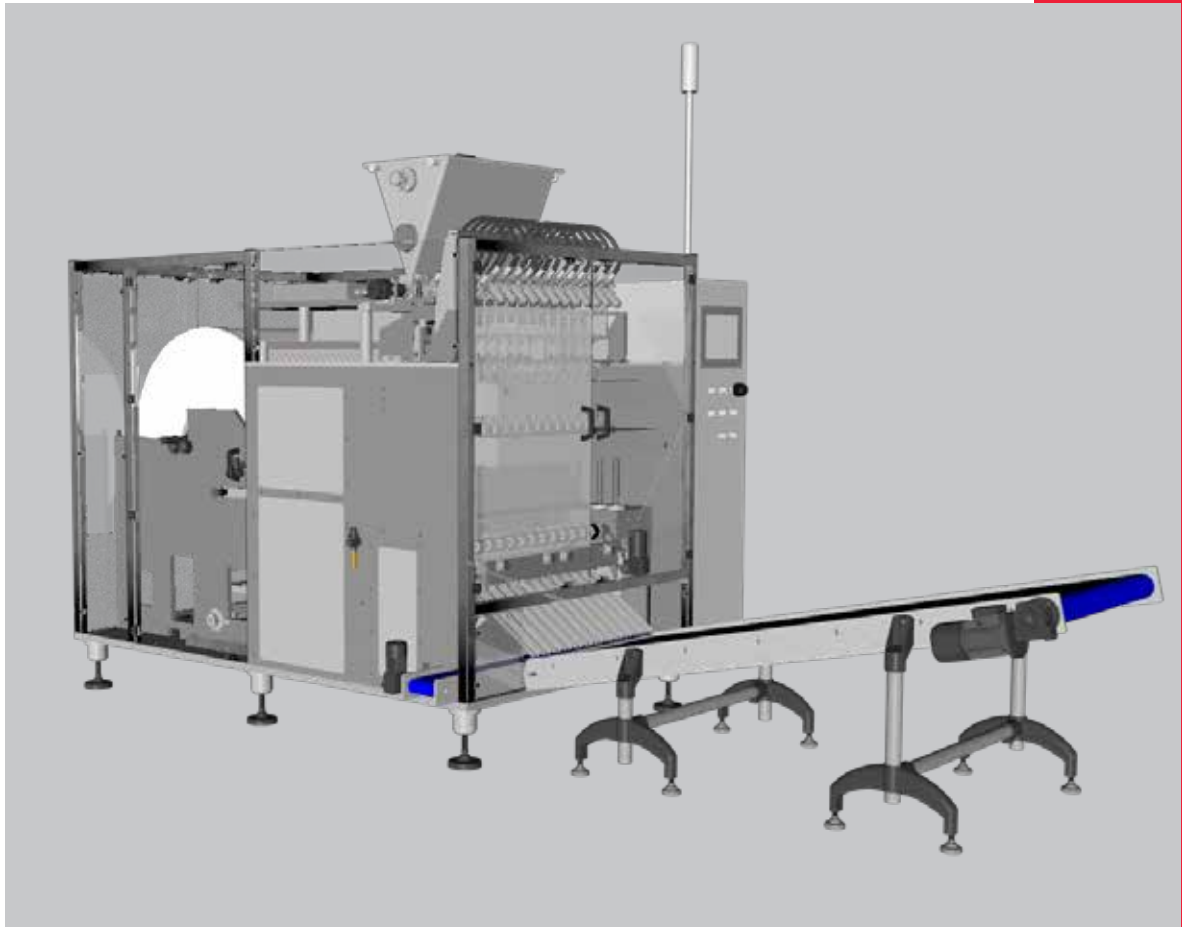

STICK + FDCP

Doser for **liquids** or **semi-liquids** (**ketchup, mayonnaise, mustard, etc**) with pumping syringes and rotating cylinder.

Volumetric feeder suitable for semidense liquids that might contain small particles.

Complete with hopper, hopper lid and suitable injection nozzles for the product to dose.

Servomotor driven doser to allow high speed and very precise control of product flow.

All the parts in contact with the product are made of stainless steel or other food grade material.

Fill products:

ketchup, mayonnaise, mustard, hair gel, BBQ sauces, disinfectant, ice lollies, detergent, tomato paste, dressings, etc.

AUTOMATIC HIGH SPEED multilane **STICKPACK** machine for the forming and filling of **3 side seal sticks**.

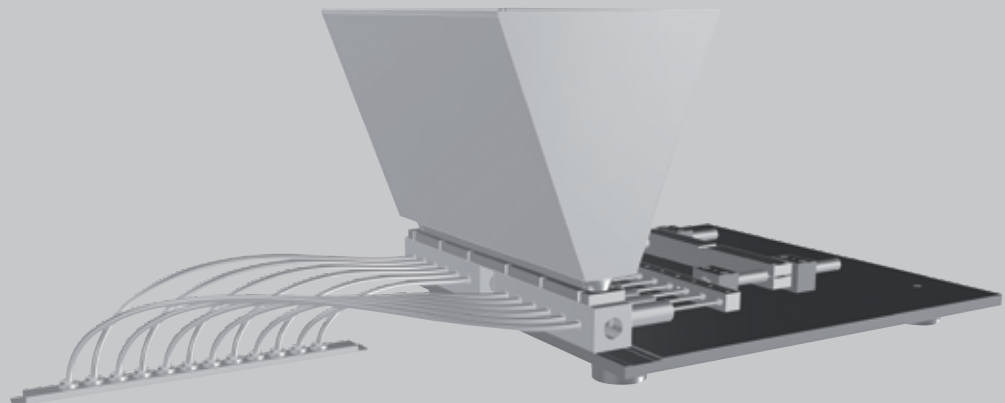
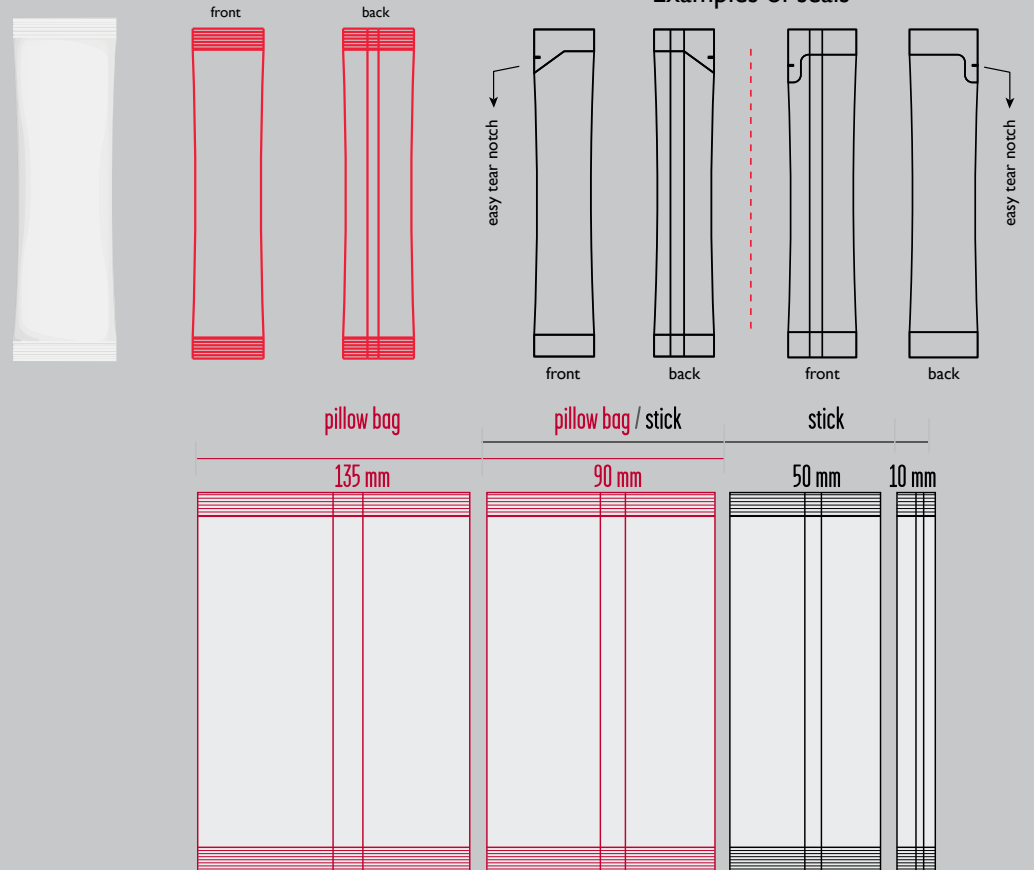

- able to handle reels of up to 900mm width and 1000mm diameter;
- machine frame in specially treated and hardened aluminium, all parts in contact with the product in AISI 316L stainless steel or foodgrade material;
- servo-driven transversal sealing jaws movement, assisted by pneumatic system;
- servo-driven reel unwinding for correct and constant control of material tension and diameter;
- constant longitudinal temperature control with individual thermocouple-thermoregulator-heater-current detector on each lane;
- double conveyor for division of full and empty sticks(while dosing unit is off);
- modem for remote troubleshooting and PLC software status diagnosis;
- basic parameters easily adjustable from control panel (output speed, sealing temperatures, enabling of various devices eg. printer, agitator, photocell control, etc.);
- various optionals available such as:
 - reel join detection;
 - easy tear notch and/or bottle neck spout;
 - dosing system accessories.

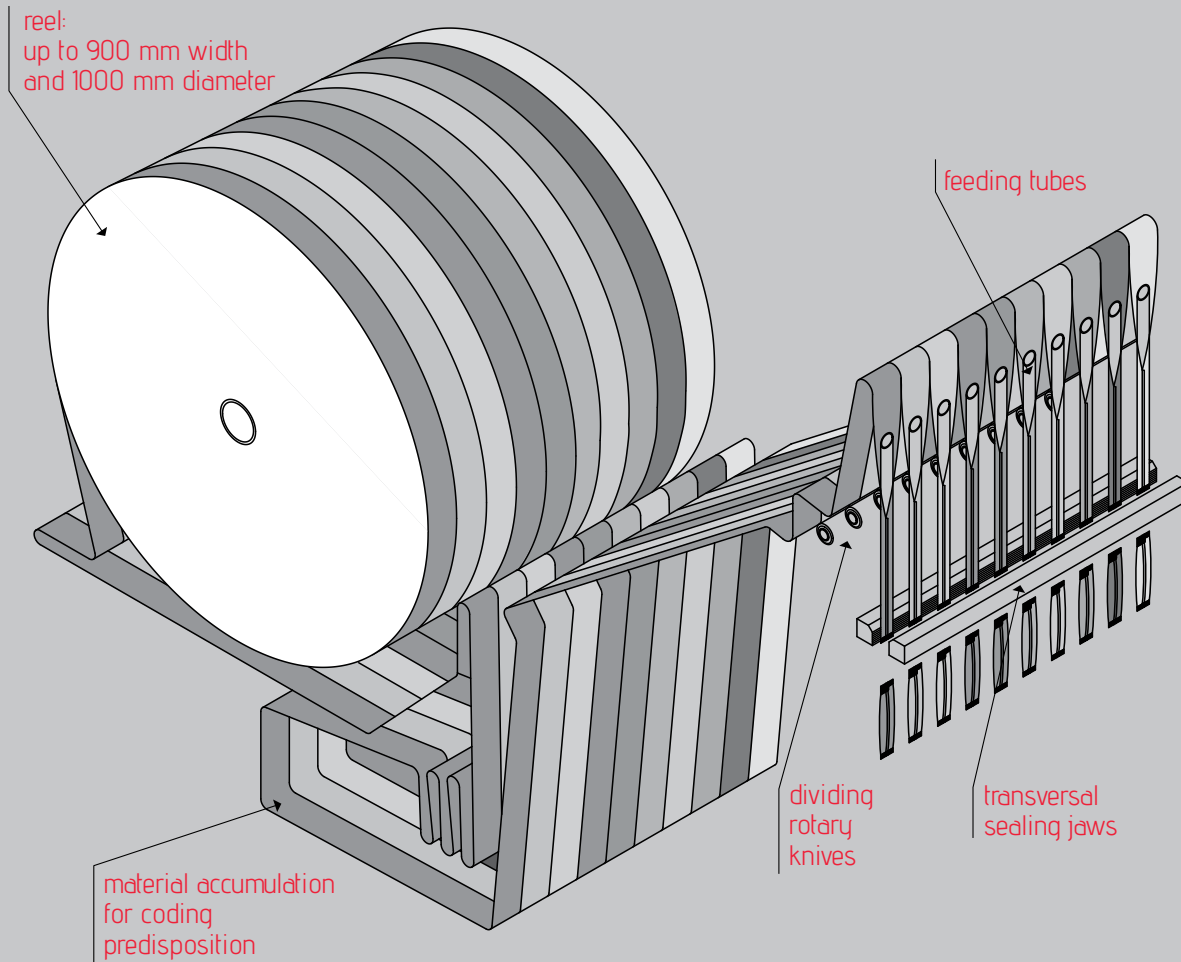

TECHNICAL DATA

max reel width	900 mm
max reel diameter	1000 mm
sachet width	min. 17 mm - max. 50 mm
max stick length	200 mm
voltage	400 V + N + PE
installed power	17 Kw
average absorption	3 - 4 Kw
air consumption	500 nl / min
dimensions	2315 x 2200 x 2400 mm



via Rosa agazzi 13
34079 Staranzano (GO)
ITALY

ph: +39 0481 484 555
fax: +39 0481 482 837

www.boatopack.com
info@boatopack.com

